

NOTE:

1. POSTS SHOWN IN VIEW ARE FOR REFERENCE ONLY.
2. BUILD PANEL ACCORDING TO BOM.

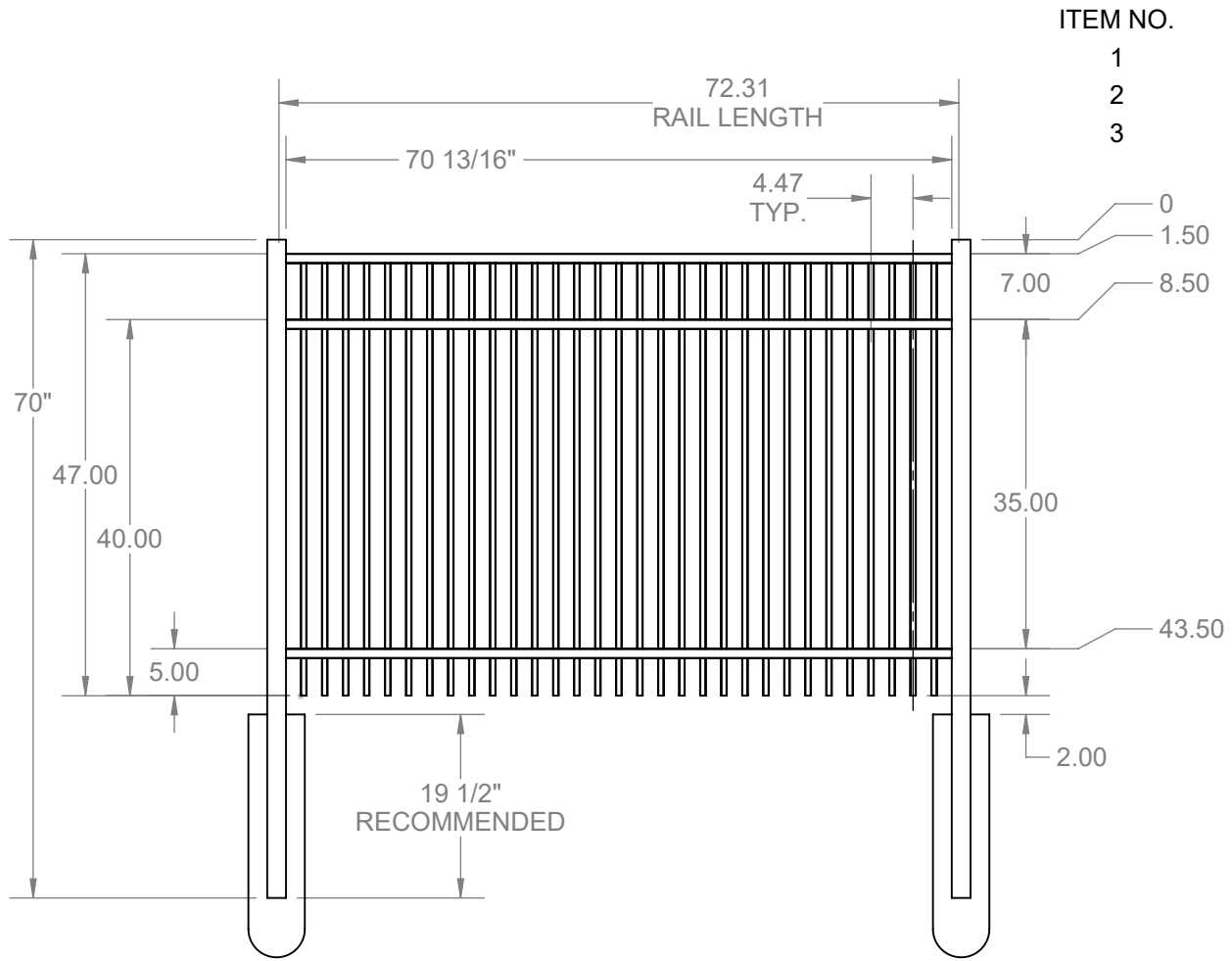

ITEM NO.	DESCRIPTION	QTY.
1	(EPN-0477) 1"X1"X6' DBL PNCHED	2
2	RES FENCE-RAIL 72.3 BK	1
3	(EPN-0663) .615"X.615"X46.813" 3-RAIL	31

4X6 DOUBLE FLAT TOP BLACK PANEL

THE INFORMATION CONTAINED IN THIS DRAWING IS PROTECTED BY COPYRIGHT AND PATENT LAWS OF THE UNITED STATES AND OTHER COUNTRIES. ANY REPRODUCTION IN PART OR AS A WHOLE WITHOUT WRITTEN PERMISSION IS PROHIBITED.